

## BRUSHLESS LS - HS

### De 7 a 31N.m

La construcción corta de los servomotores brushless LS y HS constituye una solución óptima en aplicaciones con mínimos espacios disponibles para los motores o con alta inercia de carga.

Compuestos por un rotor con imanes de ferrita, cubren la gama de 7 a 31 N.m.



### LS - Alimentación 230V

Motor	M <sub>0</sub> (N.m)	I <sub>0</sub> (A)	M <sub>N</sub> (N.m)	N <sub>MÁX</sub> (rpm)	M <sub>MÁX</sub> (N.m)	Inercia J (kgm <sup>2</sup> .10 <sup>-3</sup> )	Tamaño servovariador DIGIVEX
LS810EX	7	7.18	6.7	2000	13.2	200	7.5/15
LS810ER	7	13.9	6.1	4000	13.5	200	15/30
LS820EQ	14	14.8	13.1	2100	25.7	350	15/30
LS820EJ	14	27.8	11.6	4000	27	350	30/60
LS910EW	15	14.3	13.6	1800	28.1	680	15/30
LS910EM	15	27.9	11.4	3600	28.6	680	30/60
LS920EM	31	27.4	28	1800	59.5	1200	30/60
LS920EH	31	52.5	22.4	3400	53.2	1200	60/100

### HS - Alimentación 400V

Motor	M <sub>0</sub> (N.m)	I <sub>0</sub> (A)	M <sub>N</sub> (N.m)	N <sub>MÁX</sub> (rpm)	M <sub>MÁX</sub> (N.m)	Inercia J (kgm <sup>2</sup> .10 <sup>-3</sup> )	Tamaño servovariador DIGIVEX
HS810EZ	7	4	6.6	2200	12.7	200	4/8
HS810EY	7	6.42	6.3	3600	13.6	200	8/16
HS810EW	7	8	6	4400	12.7	200	8/16
HS820EV	14	7.76	13	2200	26.1	350	8/16
HS820EQ	14	14.8	11.3	4200	27.1	350	16/32
HS910EX	15	7.05	13.7	1700	29.1	680	8/16
HS910EW	15	14.3	11.4	3600	29.1	680	16/32
HS920EW	31	7.51	29.9	900	58.3	1200	8/16
HS920ET	31	15	27.8	1900	58.3	1200	16/32
HS920EL	31	30	20.5	3800	58.3	1200	32/64

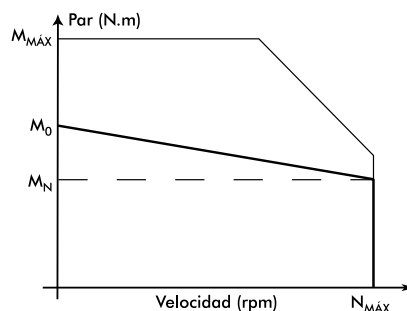
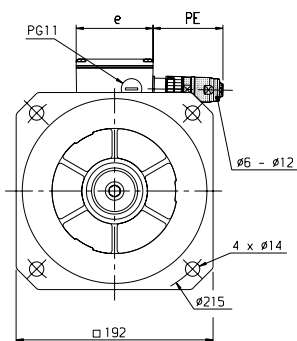
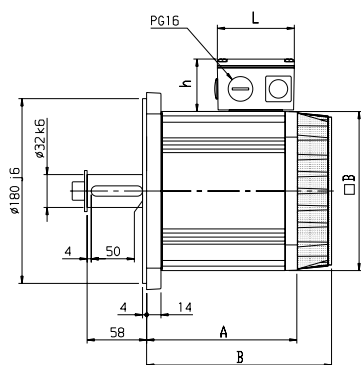

### Medidas LS-HS

Motor	L (mm)	h (mm)	e (mm)	PE (mm)	□B (mm)	A <sup>(1)</sup> (mm)	B <sup>(2)</sup> (mm)	Peso (kg)	Fr* (daN)	Fa* (daN)
LS810	76	51	76	91	155	144	182	10.4	65	45
LS820	76	51	76	91	155	185	223	14.6	70	50
LS910	95	65	95	91	192	166	200	17	105	40
LS920	95	65	95	91	192	216	259	25.2	120	40
HS810	76	51	76	91	155	144	182	10.4	65	45
HS820	76	51	76	91	155	185	223	14.6	70	50
HS910	95	65	95	91	192	166	200	17	105	40
HS920	95	65	95	91	192	216	259	25.2	120	40

(1) : sin freno (2) : con freno  
\* Fr y Fa no acumulables ; a 3000 rpm

**CONSTRUCCIÓN CORTA  
RED 230V Y 400V**

**IMANES DE FERRITA**

**CONECTOR RESOLVER Y CAJA DE  
BORNAS DE POTENCIA**

**OPCIÓN FRENO**

**AISLAMIENTO CLASE F**

**PROTECCIÓN IP64, OPCIÓN IP65**

## BRUSHLESS LX - HX

### De 6.7 a 320N.m

Los servomotores brushless LX y HX se caracterizan por su muy amplio rango de par y su alta relación Par / Inercia. Están especialmente diseñados para las aplicaciones de servosistemas exigentes, particularmente cuando se requieren altas capacidades dinámicas.



**CONSTRUCCIÓN DE BAJA INERCIA**

**RED 230V Y 400V**

**ALTA DINÁMICA**

**IMANES DE TIERRAS RARAS**

**CONECTOR RESOLVER Y CAJA DE BORNAS DE POTENCIA**

**OPCIÓN FRENO**

**AISLAMIENTO CLASE F**

**PROTECCIÓN IP64, OPCIONAL IP65**

### LX - Alimentación 230V

Motor	M <sub>0</sub> (N.m)	I <sub>0</sub> (A)	M <sub>N</sub> (N.m)	N <sub>MÁX</sub> (rpm)	M <sub>MÁX</sub> (N.m)	Inercia J (kgm <sup>2</sup> ·10 <sup>-3</sup> )	Tamaño servovariador DIGIVEX
LX440CL	6.7	7	6.1	2200	13.6	34	7.5/15
LX440CC	6.7	14.7	5.2	4700	13.0	34	15/30
LX440CB	6.7	19	4.6	6000	15.5	34	30/60
LX820DH	19	27.6	16.1	2800	38.4	230	30/60
LX820DF	19	36.8	13.9	3800	42.6	230	60/100
LX820VK <sup>(1)</sup>	28	29.8	26.7	2000	48	230	30/60
LX820VF <sup>(1)</sup>	28	54.6	22.8	3800	45.1	230	60/100
LX840DG	38	29.6	32.5	1600	72.8	420	30/60
LX840DE	38	41.4	28.4	2200	83.8	420	60/100
LX840VE <sup>(1)</sup>	54	59.7	46.8	2200	83.8	420	60/100

### HX - Alimentación 400V

Motor	M <sub>0</sub> (N.m)	I <sub>0</sub> (A)	M <sub>N</sub> (N.m)	N <sub>MÁX</sub> (rpm)	M <sub>MÁX</sub> (N.m)	Inercia J (kgm <sup>2</sup> ·10 <sup>-3</sup> )	Tamaño servovariador DIGIVEX
HX440CW	6.7	3.5	6.2	2100	14.4	34	4/8
HX440CR	6.7	4.9	5.9	3000	15.5	34	8/16
HX440CK	6.7	7.4	5.3	4500	13.7	34	8/16
HX440CH	6.7	9.5	4.7	5800	15.5	34	16/32
HX820DT	19	7.9	18.1	1500	36.4	230	8/16
HX820DN	19	15.8	15.5	3100	36.4	230	16/32
HX820DJ	19	22.1	12.8	4200	42.5	230	32/64
HX820VK <sup>(1)</sup>	28	29.8	22.2	4000	50	230	32/64
HX820VH <sup>(1)</sup>	28	41	18.7	5000	47	230	50/80
HX840DN	38	14.8	33.1	1500	76.8	420	16/32
HX840DH	38	25.9	25	2600	85.3	420	32/64
HX840VJ <sup>(1)</sup>	55	30.5	47.4	2100	100.5	420	32/64
HX840VG <sup>(1)</sup>	55	43.5	40.6	3100	91.3	420	50/80
HX840VG <sup>(1)</sup>	55	43.5	40.6	3100	112.9	420	100/120
HXA30VI <sup>(1)</sup>	170	98.8	123.9	2000	190.7	2700	100/120
HXA40VI <sup>(1)</sup>	228	99.6	185.9	1400	254	3500	100/120
HXA40VG <sup>(1)</sup>	230	130	170.9	1900	250	3500	150
HXA40VE <sup>(1)</sup>	230	182	147.7	2700	243	3500	200
HXA50VF <sup>(1)</sup>	280	146	213	1800	284	4300	150
HXA50VE <sup>(1)</sup>	280	175	204	2150	303	4300	200
HXA60VF <sup>(1)</sup>	320	136	262	1450	339	5100	150
HXA60VD <sup>(1)</sup>	315	199	206	2200	315	5100	200

<sup>(1)</sup> Motor ventilado

